

# Shop-Made Router Lift

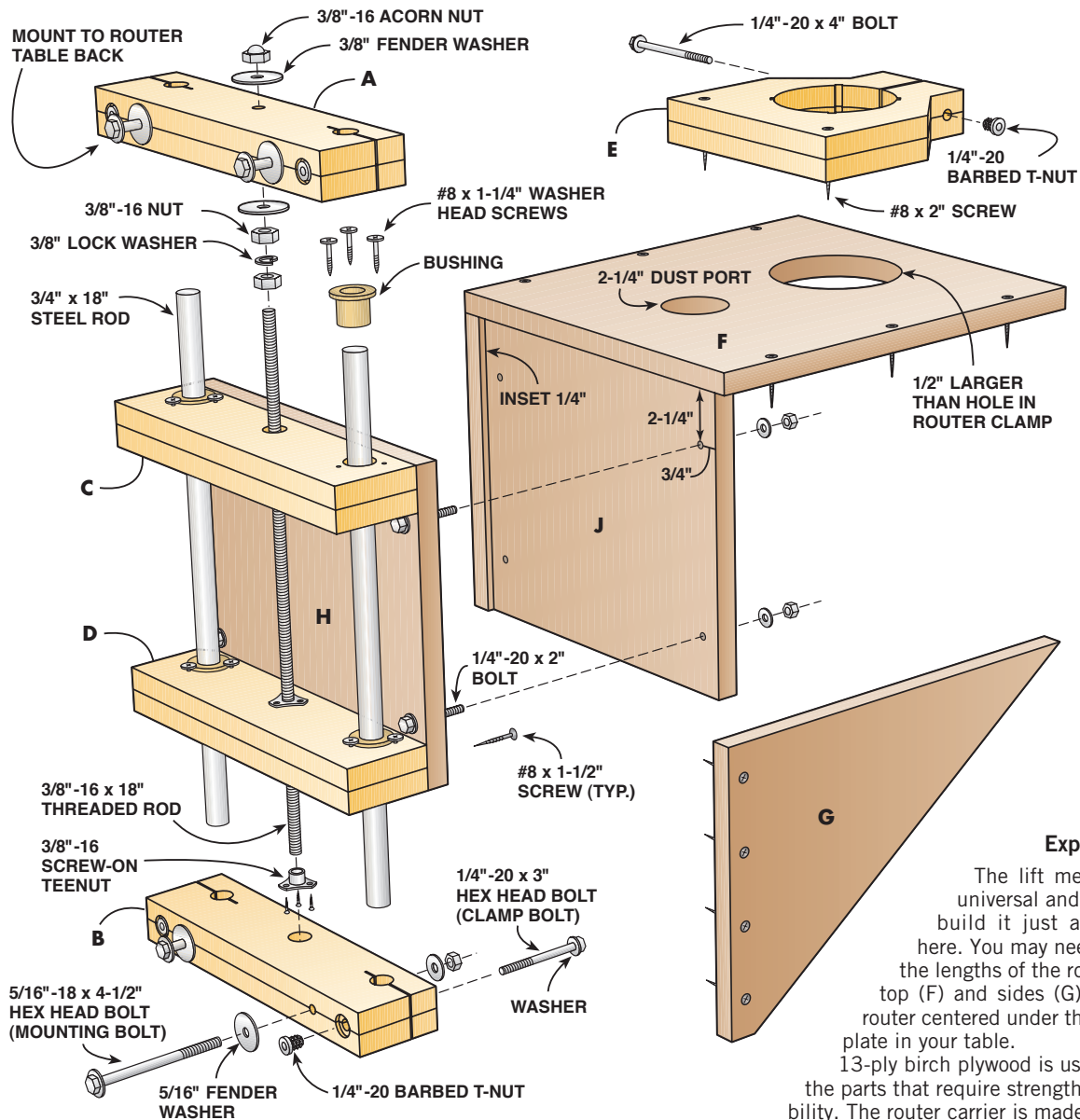

**Fig. A**  
**Exploded View**

The lift mechanism is universal and you should build it just as we show here. You may need to adjust the lengths of the router carrier top (F) and sides (G) to get the router centered under the mounting plate in your table.

13-ply birch plywood is used for all the parts that require strength and stability. The router carrier is made primarily of MDF or other sheet stock.

Fig. B Upper Clamp Block

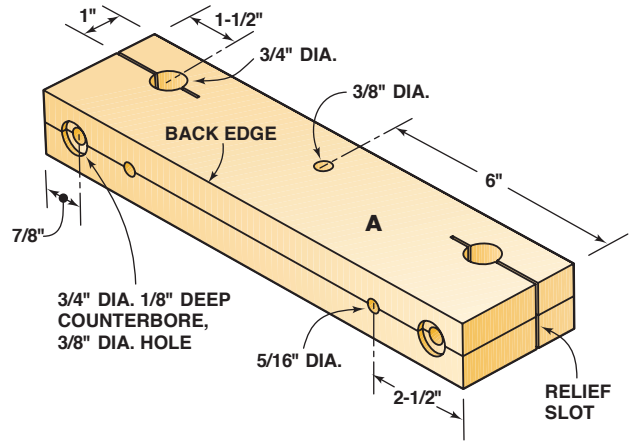

Fig. C Upper Slide Block



Fig. D Lower Slide Block

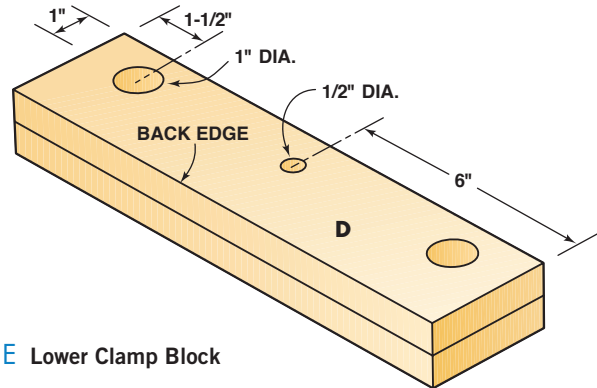

Fig. E Lower Clamp Block

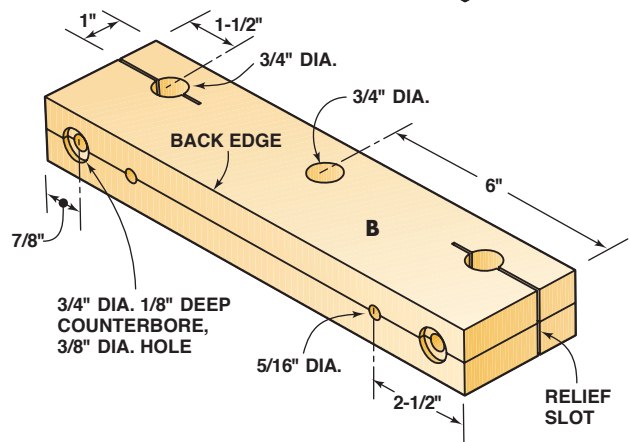

Fig. F Router Clamp

